



H Series Etching Presses

The "Top Line" Etching Presses.



The extra-large diameter rollers (9.4 to 10.6 inches) ensure uniform pressure distribution.

Rollers are supported by oversized, maintenance-free bushings.

The large ratio gearbox and the large 5 spokes wheel, provide easy and smooth printing. The gearbox is mounted on the upper roller.

The bed plate is made of 10mm high strength steel and has a 1mm galvanized steel cover. It is supported and guided by adjustable roller bearings and has elastic stops at the ends.

Press is supported by 4 swivel, adjustable height feet, so it can be placed on uneven ground.

Pressure gauges, with 0.1mm accuracy, provide ease of height adjustment when using different materials

Maximum opening: 1.6 inches (3.9 upon request).

H Series Etching Presses



Technical Data

	H70x100	H85x130	H100x150	H100x200	H120x180	H150x250
Upper Roller Diameter <i>inch</i>	9.4	9.4	9.4	9.4	10.6	10.6
Lower Roller Diameter <i>inch</i>	9.4	9.4	9.4	9.4	9.4	10.6
Reduction	1/12	1/15	1/18	1/18	1/21	1/24
Bed Plate Thickness <i>inch</i>	0.39	0.39	0.39	0.39	0.39	0.39
Bed Plate Width <i>inch</i>	29.1	35	40.9	40.9	48.8	60.6
Bed Plate Travel <i>inch</i>	48	60	67.7	87.4	79.5	107
Max Opening <i>inch</i>	1.6	1.6	1.6	1.6	1.6	1.6
Weight approx. lbs	1170	1370	1675	1810	1918	2580

Dimensions (inch)

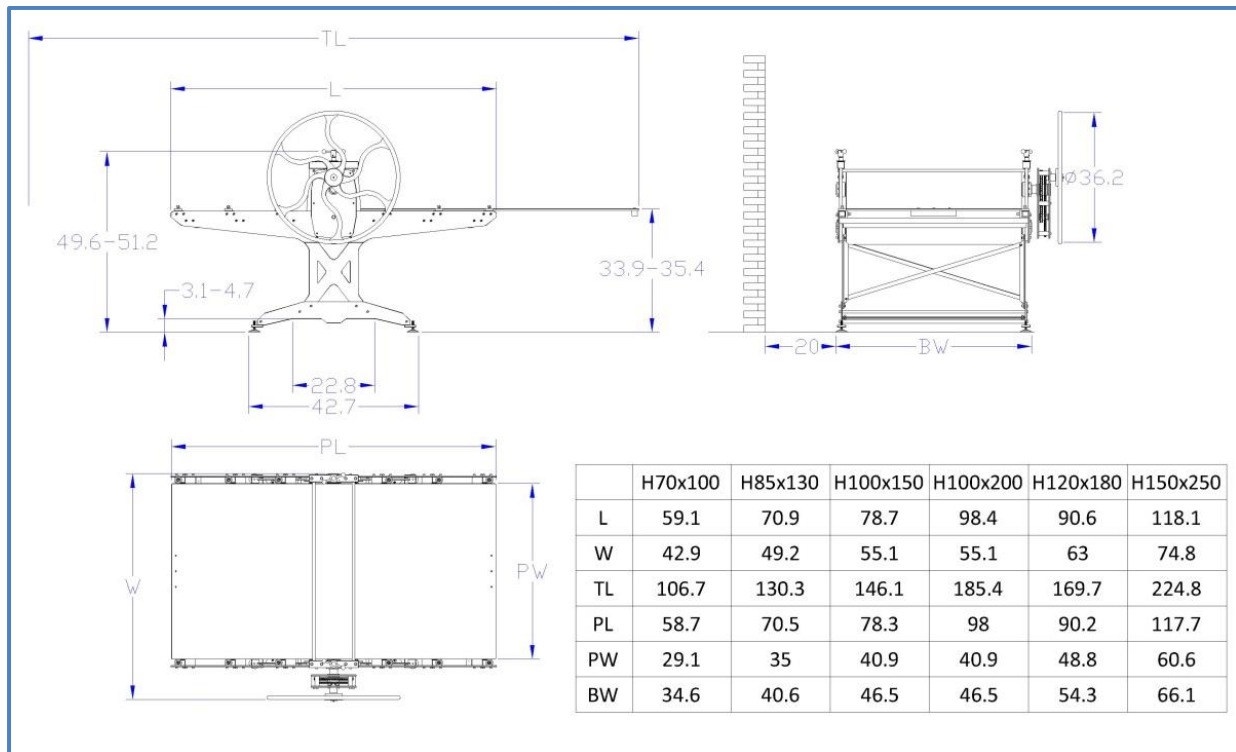

H Series Etching Presses